



10 tm

ORMIG S.p.A.

TEL. (+39) 0143 80051 r.a.
TELEFAX (+39) 0143 86568
E-mail: mktg@ormigspa.com
E-mail: sales@ormigspa.com
www.ormig.com - www.pickandcarry.com

ORMIG S.p.A.
PIAZZALE ORMIG
P.O. BOX 63
15076 OVADA (AL)
ITALY

CARATTERISTICHE TECNICHE



Telaio:	Struttura in tubolari a sezione rettangolare. Progettato e costruito dalla ORMIG con acciaio ad alta qualità.
Motore:	Diesel PERKINS 1104D-44T, 4 cilindri, 4 tempi, potenza massima 63 kW (85 CV) a 2300 giri/min. Capacità serbatoio combustibile 160 litri.
Cambio:	Convertitore di coppia 2 MA+2 RM.
Assali:	Anteriore motore, rigido. Posteriore sterzante, oscillante al centro.
Pneumatici:	8,25 - R15, 18 PR, gemellati su asse anteriore e semplici su asse posteriore.
Sterzo:	Sistema costituito da pompa idraulica, idrosterzo e cilindro idraulico a stelo passante. Raggio max di ingombro fascia esterna 4,13 m.
Freni:	Conformi alla normativa CEE. Freno di servizio con azionamento idraulico agente sulle ruote anteriori, con comando a pedale. Freno di stazionamento e di emergenza meccanico a molla agente sulle ruote anteriori, sbloccabile idraulicamente con comando azionabile dal posto di guida.
Posto di guida:	Cruscotto completo di strumentazione, comandi e volante, con sedile ergonomico e protezione conducente.
Impianto elettrico:	Tensione di esercizio 24 V. Alternatore da 55 A. Motorino d'avviamento N° 2 batterie da 100 Ah.
Braccio:	Realizzato in lamiera ad alta resistenza, collegato al telaio tramite le spalle di sostegno posteriori. Il braccio consiste in un elemento di base e di due prolunghe a sfilo oleodinamico mediante cilindri a doppio effetto. Gancio fisso in testa al braccio.
Impianto idraulico:	Alimentato da una pompa a tre sezioni. Valvola di freno e di blocco sul cilindro del braccio e delle prolunghe. Valvole tarate sui distributori del circuito idraulico. Capacità del serbatoio litri 115.
Dispositivo di controllo del carico:	Elettronico di tipo attivo con blocco delle funzioni che incrementano le situazioni di pericolo.
Norme di sicurezza:	L'autogrù è dotata di tutti i dispositivi di sicurezza previsti dalle vigenti disposizioni in materia, rispetta i requisiti essenziali di sicurezza e di salute dell'allegato I della Direttiva Macchine 2006/42/CE e successivi emendamenti, in conseguenza di ciò sulla macchina è stata appostata la marcatura "CE".
Omologazione stradale:	La gru è omologata secondo il D.M: del 14/06/85 come Macchina Operatrice a libera circolazione
Pesi:	Peso Totale 10.400 kg. - Asse Anteriore 3.400 kg - Asse posteriore 7.000 kg.
Applicazioni a richiesta:	<ul style="list-style-type: none">• Cabina di guida, completa di riscaldamento e tergicristalli• Argano con gancio, fune, fine corsa e comando• Braccetti speciali• Ruota di scorta

TECHNICAL FEATURES

Frame:	Rectangular pipes structure. Projected and manufactured by Ormig from high quality steel.
Engine:	Diesel - PERKINS 1104D-44T, 4 cylindres, 4 strokes, 63 kW max power (85 HP) at 2300 rpm Fuel tank capacity: 160 litres.
Speed gearbox:	Torque converter, 2 forward and 2 reverse speeds.
Axles:	Front rigid driving axle. Steering rear axle with central swing.
Tyres:	8.25 – R15, 18PR double tyres at front axle and single at rear axle.
Steering:	Equipped with hydraulic pump, hydraulic steering and hydraulic cylinder with going through stem. Max. outer turning circle radius 4.13 m
Brakes:	In compliance with EEC regulations. Hydraulically operated service brake acting at front wheels, at foot pedal control. Spring type mechanical parking and emergency brake, acting at front wheels; hydraulic desengagement is provided with control from driving cab.
Driving place:	Dashboard with full instrumentation, controls and steering-wheel, with ergonomic seat and driver protection.
Electric system:	24 V - 55 A alternator - Starting motor - 2 batteries of 100 Ah
Boom:	Fabricated from plate at high strength. It is connected to the frame by means of the rear supporting parts. The boom is formed by a base section and two extensions at oleodynamic extraction through duple-action cylinder. Fix hook at boom top.
Hydraulic system:	Equipped with a 3-sections pump. Braking and locking valve on the boom and extentions cylinder. Calibrated valves on the distributors of the hydraulic system. Tank capacity 115 litres.
Safety regulations:	The crane is fitted with all safety devices as per regulations in force; it complies with safety and health rules as per Encl.1 of Machine Directive 2006/42/CE and subsequent amendment. Therefore, the mark "CE" is provided on the crane equipped with the electronic safe load device.
Weight:	Total weight 10.400 Kg Front axle 3.400 Kg Rear axle 7.000 Kg
Equipment on request:	<ul style="list-style-type: none">• Electronic safe load device, active type, providing cut out of the controls which can cause dangerous conditions when the rated load is reached• Driving cab, complete with heater and windshied wiper• Winch with hook, rope, end of stroke and control• Special flyjibs• Spare wheel

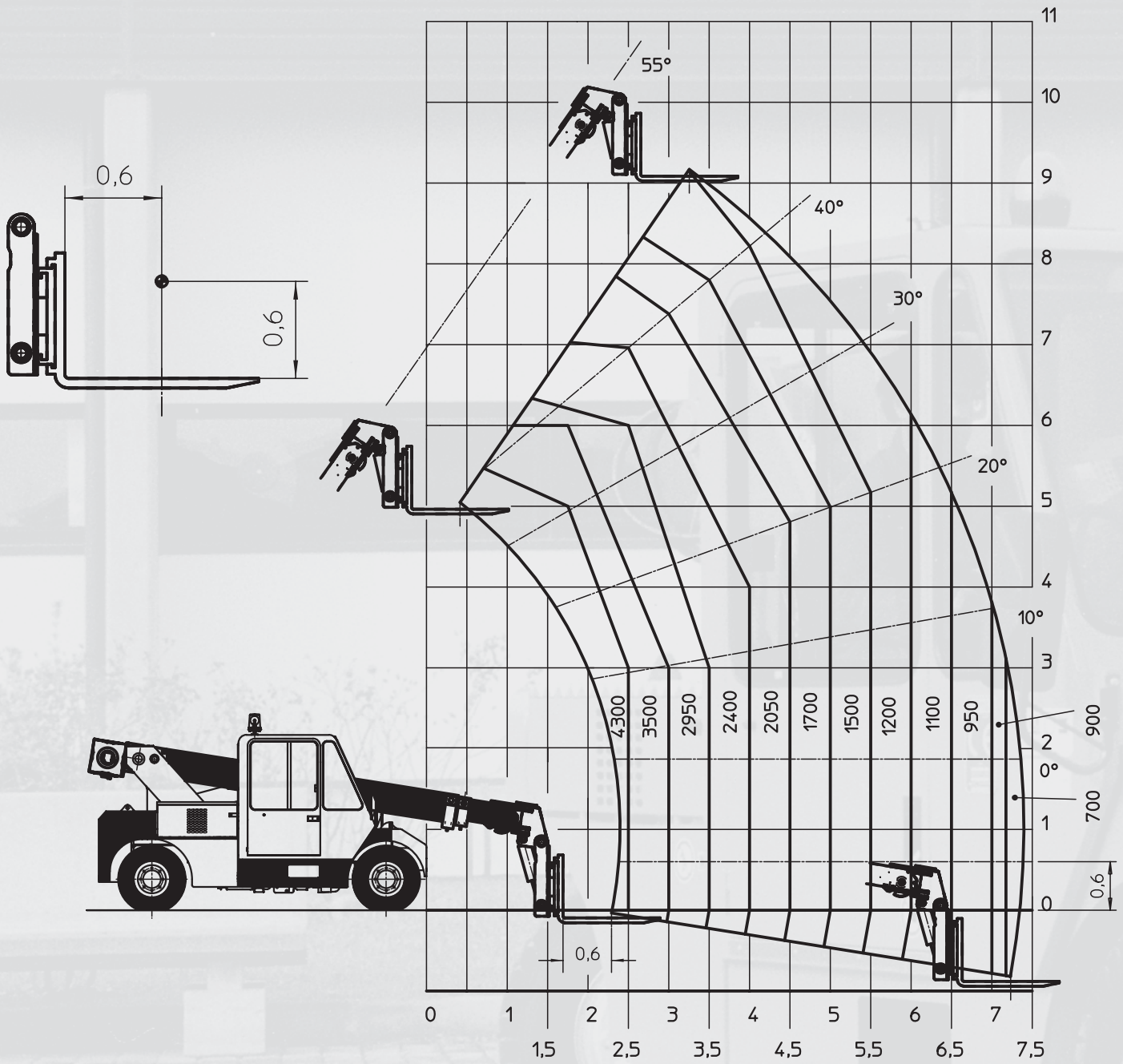

Lifting capacity chart (tonnes)

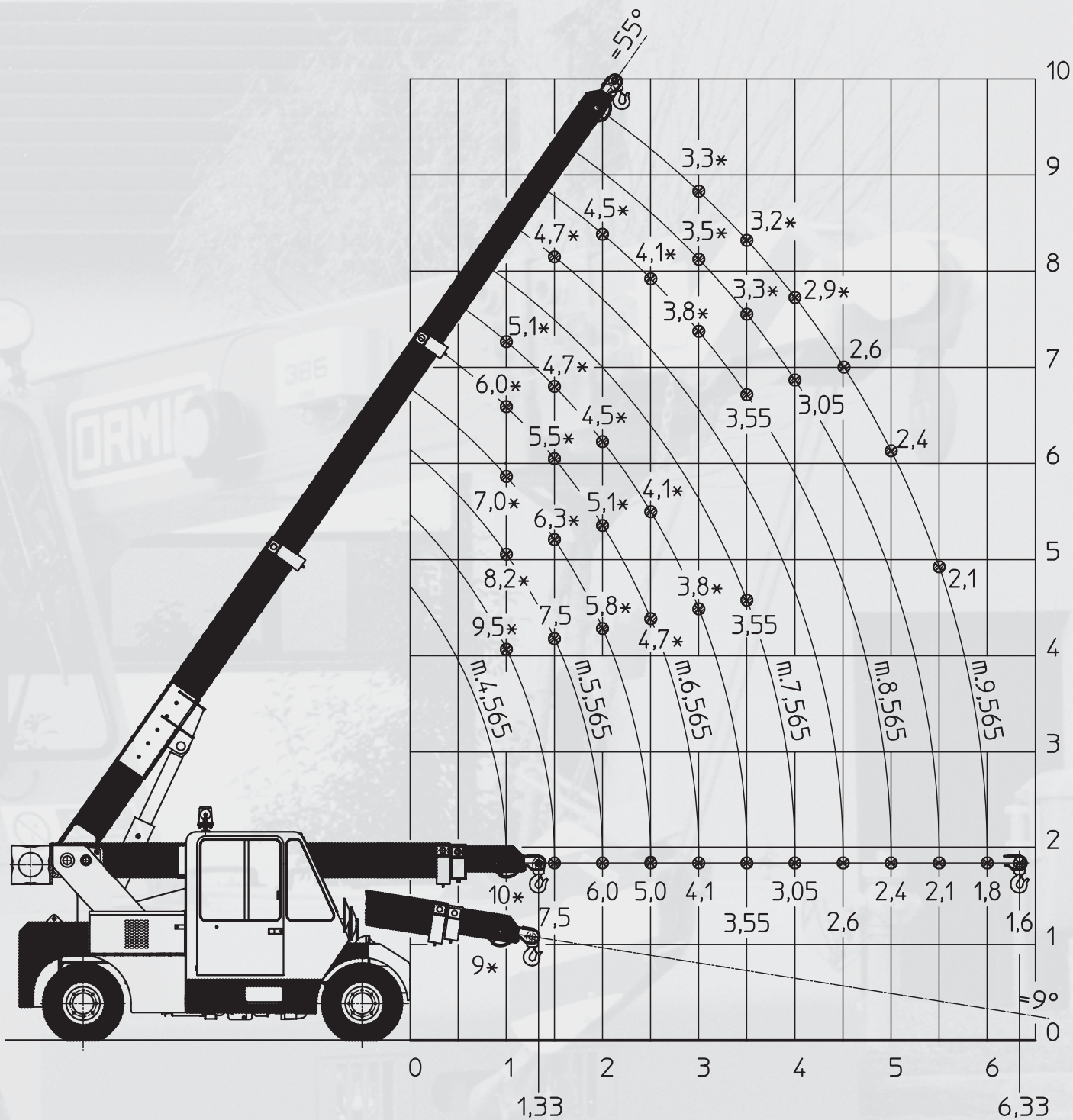

* Portate determinate da fattori diversi dal ribaltamento
 * Capacities determined by factors other than tipping load

Lifting capacity Chart with fix hooks (tonnes)

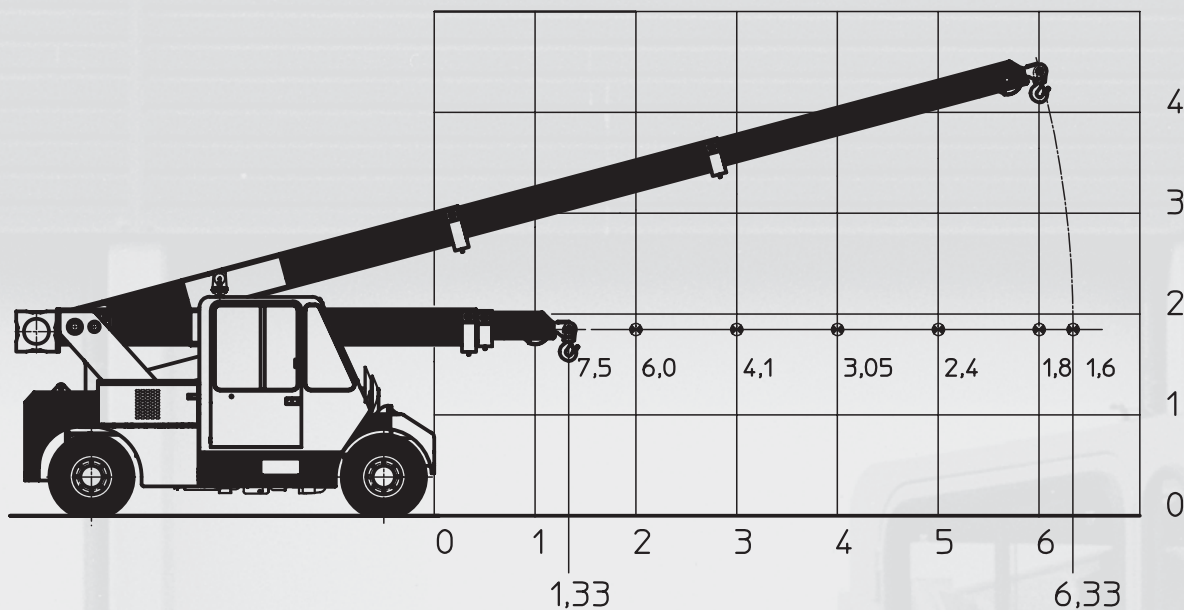

Lifting capacity Chart with fly - jibs (tonnes)

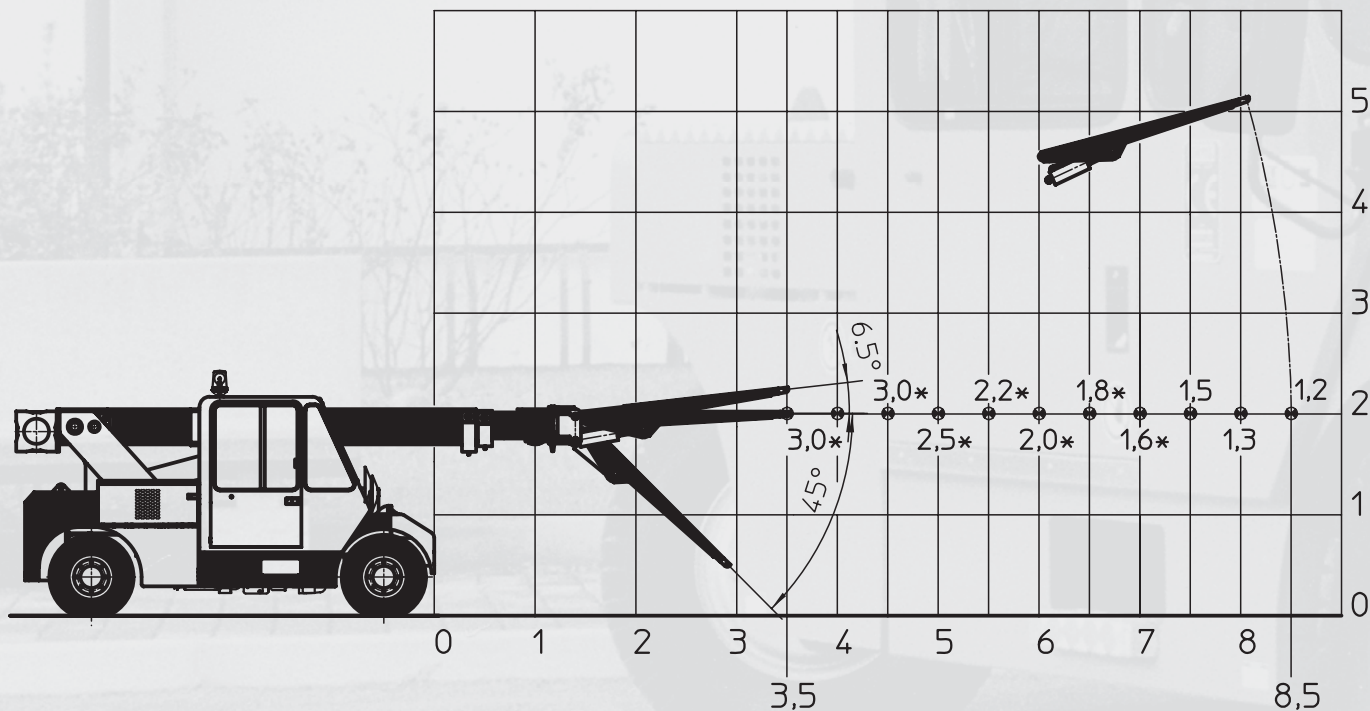

* Portate determinate da fattori diversi dal ribaltamento
 * Capacities determined by factors other than tipping load

Dimensioni Generali

General Dimensions

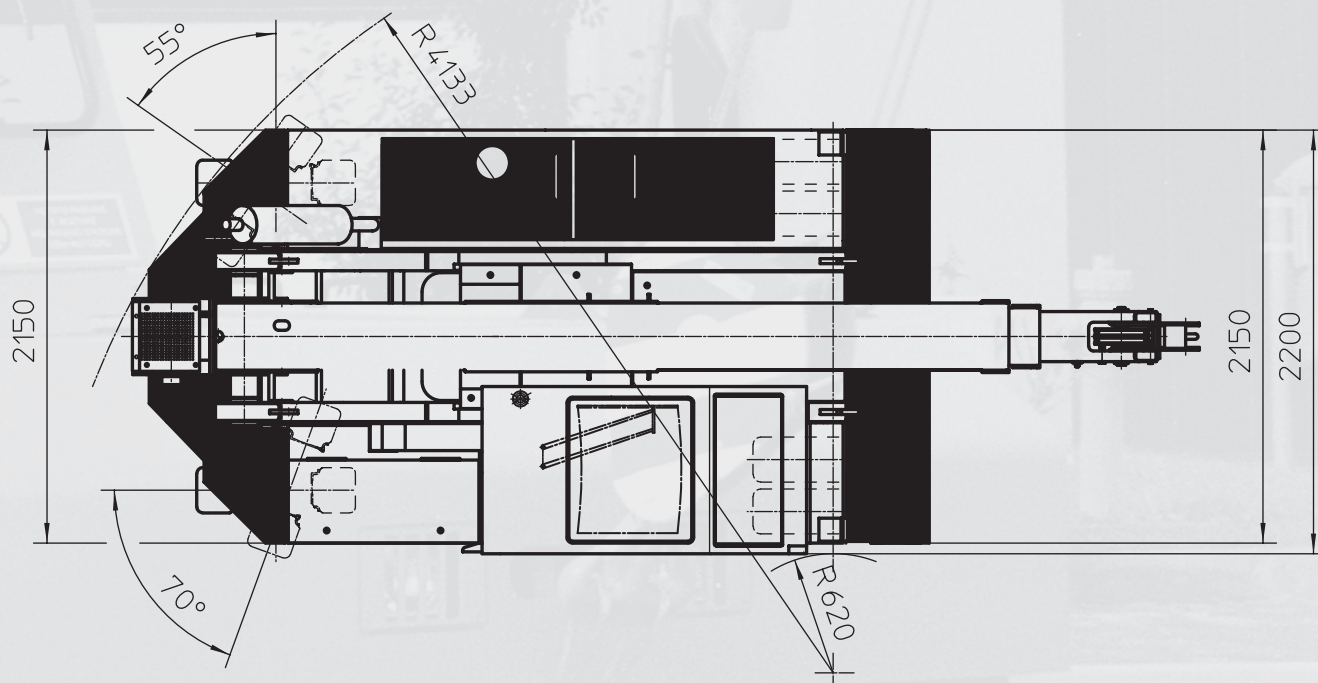
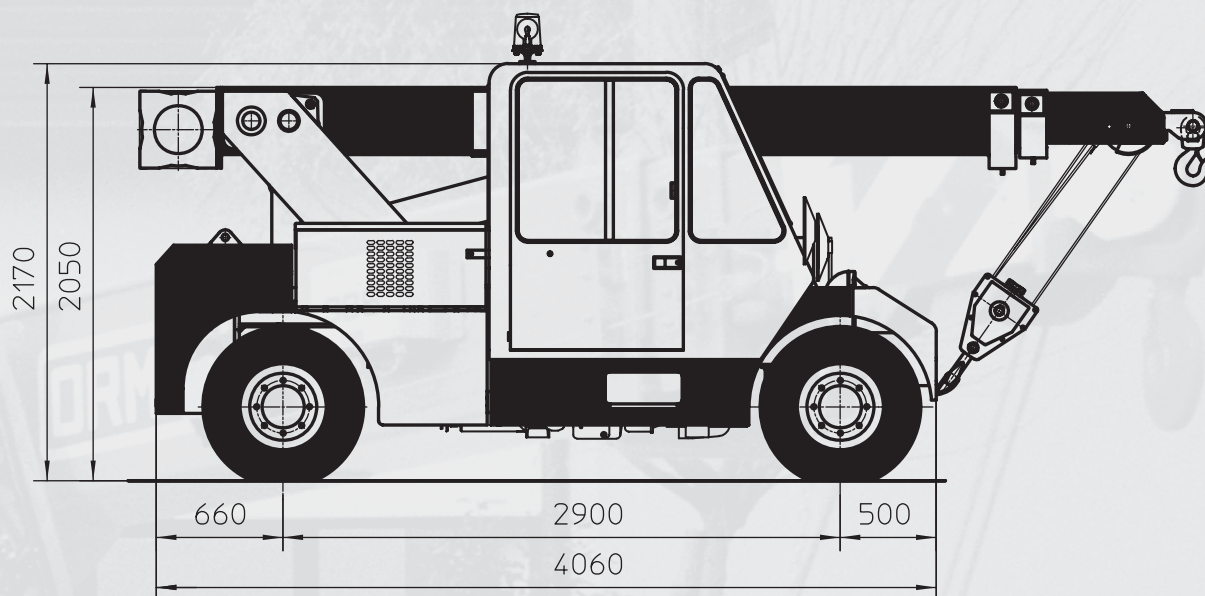



TEL. (+39) 0143 80051 r.a.
TELEFAX (+39) 0143 86568
E-mail: mktg@ormigspa.com
E-mail: sales@ormigspa.com
www.ormig.com - www.pickandcarry.com

ORMIG S.p.A.
PIAZZALE ORMIG
P.O. BOX 63
15076 OVADA (AL)
ITALY